

## Rectifier

Variable ratio transformer  
and Thyristor Technology

Oil Cooling

Oil-Water Cooling

This design is still a strong and reliable basis for applications under difficult industrial conditions. The adjustment of the rectifier can be carried out by means of a motor-driven variable ratio transformer or electronically by means of thyristors.

**Product Advantages**

- Robust construction for aggravating industrial applications
- High safety
- High protection grade NEMA 12

ditto-graphics.com | 07.10 | 1.000 | DD

## Rectifier

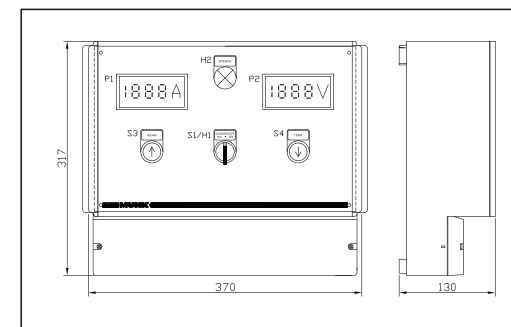
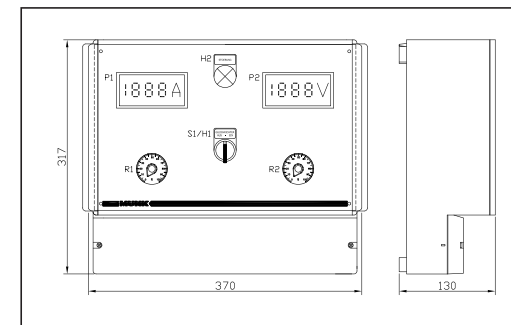
oil-cooled and  
oil-water-cooled**Remote control (higher / lower)****Remote control (with constant current or voltage control):****Measuring Instruments (standard)**

- Digital for current and voltage

**Further Options**

- Phase protection
- Ah meter
- Constant current or voltage control
- Polarity change function
- Field bus interface
- Silikagel air de-hydration
- Smoothing device to reduce the ripple

**Technical Data (standard)**

Mains voltage	3 x 480 V/60 Hz + N + PE (further voltages on request)
Adjustment	stepless from 0 - 100 %
Ripple: Variable ratio transformer Thyristor technology	5 % full range approx. 5 - 7 % at full load
Duty factor	100 % ED
Ambient temperature	+ 95°F
Water entry temperature (only for type MxOW)	+ 60.8°F up to + 86°F
Insulating oil	accord. to IEC Publication 2/96
Operating altitude	up to 1000 m above sea level
Surface finish	light grey
Supervision	oil temperature, overcurrent relay
Protection grade	NEMA 12 - NEMA 4

Technical changes reserved.

AMERICAN

PLATING POWER

**American Plating Power, LLC**  
13300-56 S.Cleveland Ave. Suite 215  
Fort Myers, FL 33907  
USA  
Phone +1 239 275 5877  
Fax +1 239 275 4959  
www.americanplatingpower.com  
sales@americanplatingpower.com

Partner in Europe:

**Munk GmbH**  
Gewerbepark 8 + 10  
59069 Hamm  
Germany  
Phone +49 2385 740  
Fax +49 2385 7455  
www.rectifier.com  
sales@rectifier.com

# Rectifier Type MxO oil-cooled

# Rectifier Type MxOW oil-water-cooled

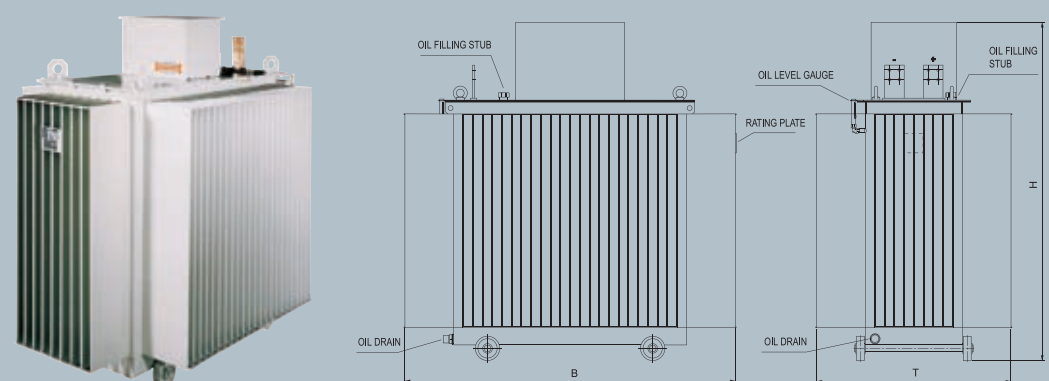

The main components are built into a corrugated steel tank. Due to the high protection grade (NEMA 12) the device can be located directly in an aggravating environment. The heat loss is convected by means of the corrugated surface.

### MxO rectifier available types (tank/ weight empty [lbs])

I/A	6V	8V	10V	12V	15V	18V	20V	22V
100	F1/330	F1/365	F1/400	F1/420	F1/450	F1/475	F2/510	F2/530
200	F1/465	F1/495	F2/520	F2/540	F2/575	F2/595	F2/630	F2/650
300	F1/485	F2/520	F2/585	F2/650	F2/680	F3/730	F3/775	F3/815
400	F2/575	F2/620	F2/650	F2/700	F2/795	F3/840	F3/870	F3/815
500	F2/620	F2/675	F2/730	F2/800	F2/840	F3/860	F3/905	F3/950
600	F2/650	F2/695	F2/785	F2/820	F3/870	F4/915	F4/970	F4/1015
800	F3/730	F3/795	F3/855	F3/970	F4/950	F5/1015	F5/1080	F5/1135
1000	F3/840	F3/870	F3/915	F3/970	F4/1040	F6/1090	F6/1170	F6/1235
1200	F4/1060	F4/1125	F4/1190	F4/1460	F4/1525	F8/1565	F8/1610	F8/1790
1500	F4/1345	F5/1415	F6/1500	F6/1610	F8/1700	F9/1830	F9/1960	F10/2360
2000	F6/1520	F6/1565	F7/1700	F7/1830	F9/1960	F9/2075	F9/2250	F11/2625
2500	F8/1635	F8/1745	F8/1900	F8/2075	F9/2400	F11/2600	F11/2800	F12/3000
3000	F9/2130	F9/2240	F9/2450	F9/2625	F10/2735	F12/3350	F12/3690	F12/3860
4000	F10/2800	F10/2845	F10/3065	F10/3330	F12/3815	F12/4080	F13/4350	F13/4630
5000	F11/2940	F12/3485	F12/3650	F12/3925	F12/4013	F13/4215	F13/4770	F13/4940
6000	F12/3420	F12/3505	F13/3925	F13/4125	F13/4300	F14/4590	F14/4960	F14/5295
7000	F12/3485	F13/3640	F13/4125	F13/4250	F14/4500	F14/4720	F14/5515	F14/5845
8000	F13/3620	F13/3950	F14/4280	F14/5525	F15/5625	F16/6595	F16/7500	F16/8050
9000	F13/3860	F14/4145	F15/4520	F16/5360	F16/7235	F17/7610	F17/8600	F17/9040
10000	F14/1830	F15/1910	F15/2300	F16/2480	F16/3690	F17/4100	F17/4700	F17/4900
12000	F15/4300	F16/4855	F17/6945	F17/9925	F17/10585	F18/11135	F18/11690	
15000	F16/8600	F17/8820	F17/10800	F17/11290	F18/12570			

### MxO tank type [dimensions in inches] MxO tank type [dimensions in inches]

Type	W	D	H	Oil requirement	Type	W	D	H	Oil requirement
F1	32	19	44	353 lbs	F10	67	39	66	1565 lbs
F2	38	22	48	463 lbs	F11	81	45	69	2050 lbs
F3	45	23	52	640 lbs	F12	85	47	74	2536 lbs
F4	50	24	64	970 lbs	F13	76	64	81	4079 lbs
F5	52	26	64	1014 lbs	F14	98	58	86	6064 lbs
F6	54	28	62	1058 lbs	F15	103	63	86	6395 lbs
F7	56	30	63	1102 lbs	F16	106	67	86	6527 lbs
F8	61	32	63	1279 lbs	F17	110	83	86	9040 lbs
F9	62	35	65	1455 lbs	F18	116	83	95	10650 lbs

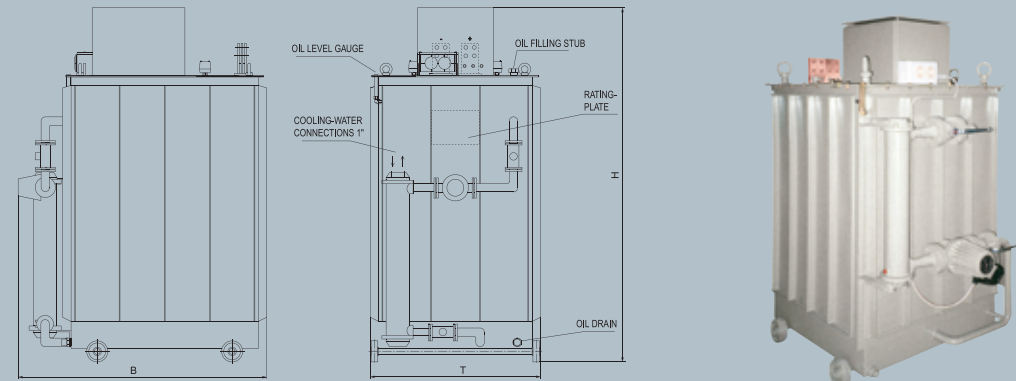

This design allows a more compact integration of high power. The smooth steel tank contains all power components and dissipates a low amount of the heat loss. By means of heat exchanger and circulation pump the main amount of the heat loss is given to the cooling circuit.

### MxOW rectifier-overview of model (tank/ weight empty [lbs])

I/A	6V	8V	10V	12V	15V	18V	20V	22V
4000	G01/2870	G01/3050	G01/3480	G01/3660	G01/3770	G01/3990	G01/4125	G01/4410
5000	G01/3000	G01/3175	G01/3660	G01/3770	G01/3880	G01/4100	G01/4235	G02/4520
6000	G01/3220	G01/3400	G01/3810	G01/4015	G01/4190	G01/4475	G01/4630	G02/5180
7000	G01/3375	G01/3530	G01/4015	G01/4125	G02/4390	G02/4610	G02/4960	G03/5510
8000	G01/3550	G01/3840	G02/4170	G02/4455	G02/4630	G04/4960	G04/5180	G04/5735
9000	G01/3860	G02/4035	G02/4410	G03/4590	G03/4920	G05/5290	G05/5510	G05/6020
10000	G01/3925	G02/4100	G02/4520	G03/4700	G03/5160	G05/5625	G05/5735	G05/6285
12000	G04/4190	G04/4740	G05/5070	G05/5400	G05/6060	G05/6615	G05/7170	u.r.
15000	G04/5400	G05/6065	G03/6620	G05/7170	G05/8050	upon request		u.r.

### Assessing of copper connection cross-section for MxO and MxOW [dimensions in inches]

DC output bars		
DC-current [A]	Qty	CU-cross-section
200	1	1.2 x 0.39
400	1	1.2 x 0.39
600	1	1.2 x 0.39
800	1	1.6 x 0.39
900	1	2.4 x 0.39
1200	1	2.4 x 0.39
1500	1	3.2 x 0.39
2000	1	3.9 x 0.39
2500	1	4.7 x 0.39
3000	2	3.9 x 0.39

DC output bars		
DC-current [A]	Qty	CU-cross-section
4000	2	3.9 x 0.39
5000	2	4.7 x 0.39
6000	2	6.3 x 0.39
7000	4	3.9 x 0.39
8000	4	4.7 x 0.39
9000	4	4.7 x 0.39
10000	6	3.9 x 0.39
12000	6	3.9 x 0.39
14000	6	4.7 x 0.39
15000	6	4.7 x 0.39

### MxOW tank type [dimensions in inches]

Type	W	D	H	Oil requirement
G01	57	43	87	3087 lbs
G02	58	48	88	3307 lbs
G03	62	49	90	3969 lbs
G04	79	43	87	4233 lbs
G05	94	57	87	7143 lbs

### Rule of thumb to determine the amount cooling water for MxOW

rated DC current [A] x 0.0581 [ $\frac{g}{A}$ ] at  $\Delta T = 10K$ ;  
 $\cong$  Amount of water in gallons per hour  
 e.g. current 10,000A x 0.0581 [ $\frac{g}{A}$ ]  
 $\cong$  581 gallons per hour

Technical changes reserved.