

Pneumatically Actuated Diaphragm Valve DIASTAR Six



General

- **Size:** ¾"–2"
- **Material:** PVC, CPVC, ABS
- **Diaphragm:** EPDM
- **Actuator Material:** Glass-filled PP
- **End Connection:** Solvent cement socket, threaded, flanged,
- **Action:** FC
- **Top Works:** Threaded connection to valve body
- **Standard Pack Quantity:** 1 valve

Key Certifications

- **FDA CFR 21 177.1520:** PP and PVDF
- **FDA CFR 21 177.2600:** EPDM and FPM
- **USP 25 Class VI (physiological non-toxic):** PP

Optional Features

- **Pilot Valve:** 24VAC/DC, 110VAC, 230VAC
- **Diaphragm:** FPM, PTFE/EPDM
- **End Connection:** Alternatives available upon request
- **Face Seals:** Alternatives available upon request
- **Cleaned:** Silicone free/oil free

Sample Specification

The DIASTAR Six Valve shall be used in open/close applications and available in fail-safe to close configuration. The actuator housing shall be glass-filled polypropylene. The pneumatic connection shall be threaded BSP. The actuator bonnet to valve body connection shall be threaded with permanent markings on both the bonnet and body to ensure proper diaphragm compression. Union and spigot style bodies shall be fully molded. Standard versions shall included 304 stainless steel threaded mounting inserts. The stroke shall be indicated by a graduated indicator. ANSI flanged versions shall meet ANSI B16.5 150lb standards. All valves shall be tested in accordance to ISO9393 and designed to ISO16138 standards. All valves shall be manufactured under ISO9001 for Quality and ISO14001 for Environmental Management. Following assembly, every valve shall be tested and certified bubble tight exceeding Class VI standards. PVC valves shall meet ASTM D1784 cell classification 12454 standards. CPVC valves shall meet ASTM D1784 cell classification 23447-B standards. ABS valves shall meet ASTM D3965 cell classification 42222 standards. Valves of all materials shall be RoHS compliant.

Key Design Features

The DIASTAR Six Pneumatically Actuated Diaphragm Valve utilizes several unique design features. The bonnet to valve body connection is threaded whereas a traditionally designed diaphragm valve utilizes metal body bolts. However when a valve is used in hot line applications, the components of the valve thermally expand and contract. The thermal expansion rate of metal is significantly less than plastics, meaning the metal body bolts of a traditionally designed diaphragm valve need to be retorqued after hot line shut downs. The bonnet to body mechanical connection of the DIASTAR Six is completely plastic, thus eliminating the need for retorquing.



Technical Data

Pressure Temperature Curves

The following graphs are based on a 25 year lifetime water or similar media application

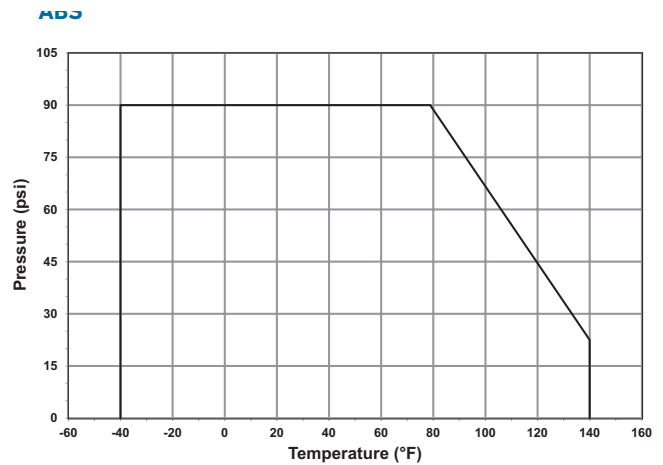
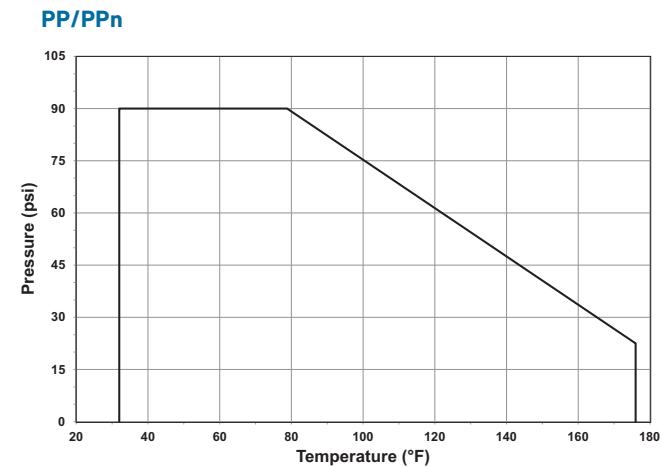
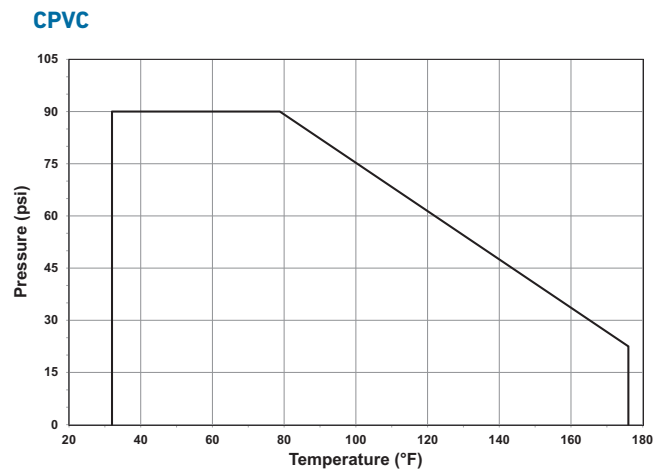
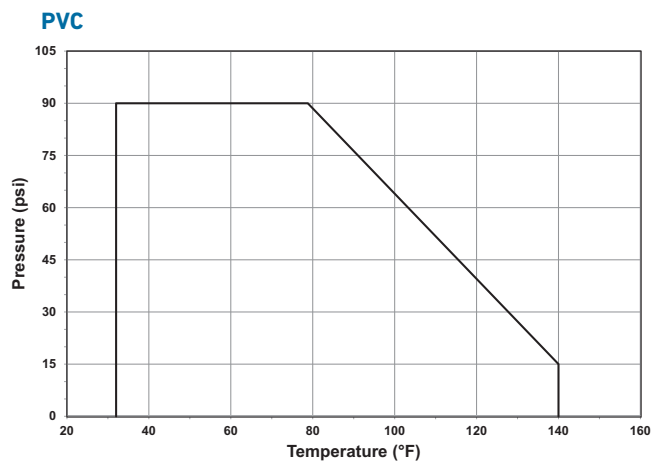

Pressure-Temperature

Material	Temperature Range (°F)	Max Pressure (psi)
PVC	32 to 140	90
CPVC	32 to 176	90
PP/PPn	32 to 176	90
ABS	-40 to 140	90

Pressure Rating

The combined upstream and downstream process line pressures shall not exceed 90psi when the valve is closed. The process line pressure shall not exceed 90psi when the valve is open.

Flow

The following information is based on water applications at 68° F

Cv Value

Size (inch)	d (mm)	Cv (gal/min)
1/2	20	8.4
3/4	25	18.3
1	32	32.5
1 1/4	40	51.3
1 1/2	50	66.8
2	63	82.2

Control Pressure EPDM

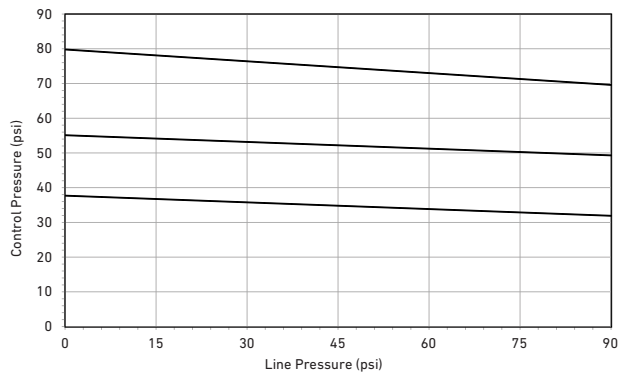

Dimensions

The following tables are shown in millimeters unless otherwise specified

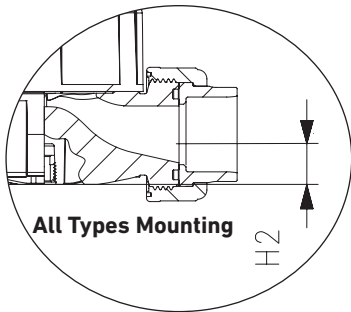

All Types Mounting

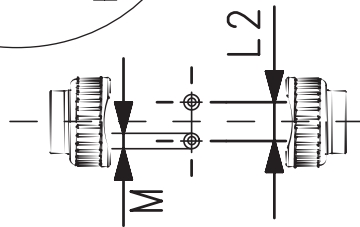

All Types Mounting Base

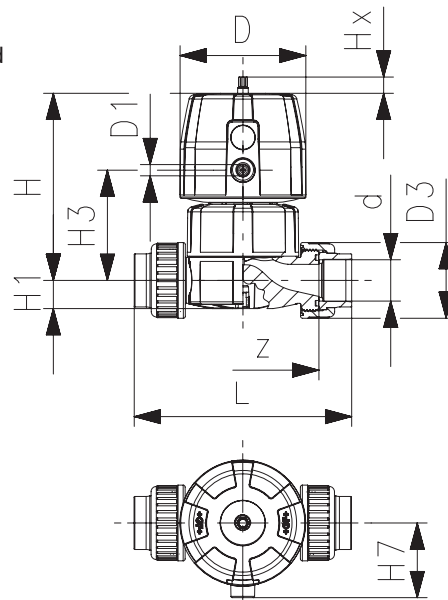

514 Socket/Threaded

All Types

Size	d (mm)	D	D1	L2	H	H1	H2	M	Hx
1/2	20	68	G1 1/8"	25	101	14	12	M6	7
3/4	25	96	G1 1/8"	25	132	18	12	M6	10
1	32	96	G1 1/8"	25	143	22	12	M6	13
1 1/4	40	120	G1 1/8"	45	173	26	15	M8	14
1 1/2	50	120	G1 1/8"	45	193	32	15	M8	16
2	63	120	G1 1/8"	45	205	39	15	M8	16

Key Design Feature

The DIASTAR Six's threaded bonnet design eliminated the need for valve body bolt holes. This allowed GF engineers to decrease the grade of the weir and design a valve with an optimized flow path. This significantly increases the Cv value when comparing the DIASTAR Six to traditionally designed diaphragm valves.

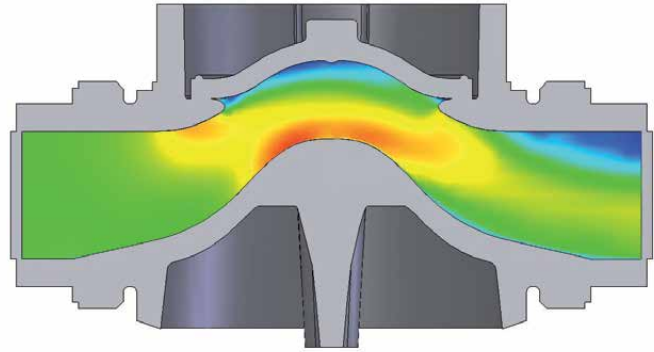

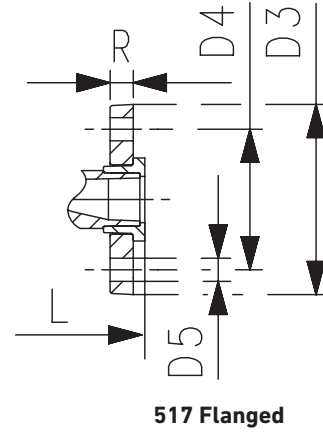
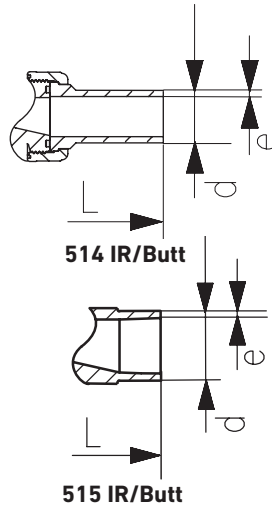
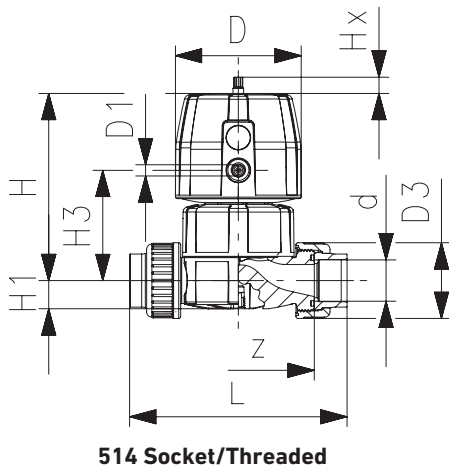

Type 514 PVC/CPVC

Size (inch)	IPS Socket		Threaded NPT	
	L	z	L	z
1/2	136	96	128	94
3/4	160	114	152	116
1	176	122	166	122
1 1/4	198	140	192	143
1 1/2	232	160	222	176
2	268	190	266	218

Type 517 PVC/CPVC

Size (inch)	ANSI Flanged				
	L	D3 (inch)	D4 (inch)	D5 (inch)	R (inch)
1/2	130	3.74	2.36	0.63	0.63
3/4	150	4.13	2.76	0.63	0.67
1	160	4.53	3.11	0.63	0.71
1 1/4	180	5.51	3.5	0.63	0.63
1 1/2	200	5.91	3.86	0.63	0.71
2	230	6.5	4.76	0.75	0.71

Type 514 PP

d(mm)	Metric IR/Butt		Metric Socket		Threaded NPT	
	L	e	L	z	L	z
20	196	1.9	128	100	132	98
25	221	2.3	150	118	154	118
32	234	2.9	162	126	172	128
40	260	3.7	184	144	196	148
50	284	4.6	210	164	222	176
63	321	5.8	248	194	266	218

Type 515 PP

d(mm)	Metric IR/Butt	
	L	e
20	124	1.9
25	144	2.3
32	155	2.9
40	176	3.7
50	193	4.6
63	223	5.8

Type 517 PP

Size (inch)	ANSI Flanged				
	L	D3 (inch)	D4 (inch)	D5 (inch)	R (inch)
1/2	130	3.74	2.36	0.63	0.63
3/4	150	4.13	2.76	0.63	0.67
1	160	4.53	3.11	0.63	0.71
1 1/4	180	5.51	3.5	0.63	0.63
1 1/2	200	5.91	3.86	0.63	0.71
2	230	6.5	4.76	0.75	0.71

Type 514 ABS

d(mm)	Metric Socket	
	L	z
20	128	96
25	152	114
32	166	122
40	192	140
50	222	160
63	266	190